

H2602 2D/3D Video Digital Microscope User Manual

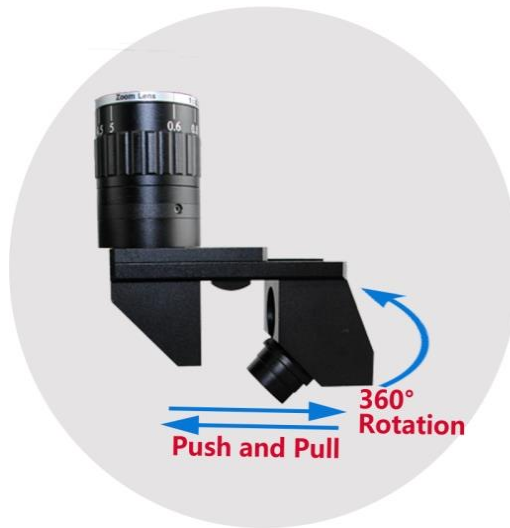
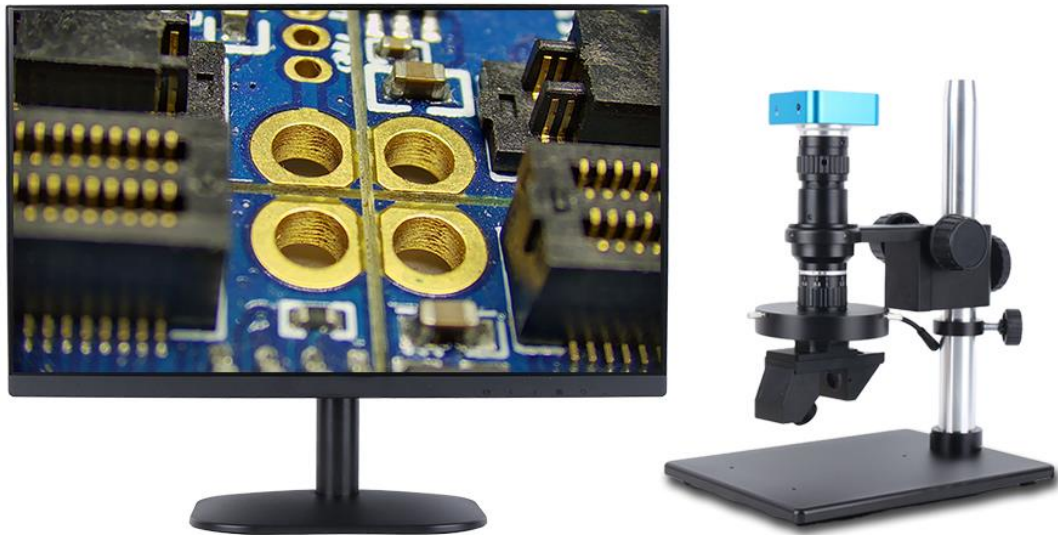

This instrument belongs to precision optical instrument. In order to ensure its service life and correct daily maintenance. Please read user manual carefully before using microscope
Thank you for purchasing our products

CONTENTS

Cautions and Notes	1
Microscope Specification	1/2
Main Feature.....	1
Optical Parameter.....	2
Microscope structure and components	3
Microscope Install Instructions	3/4
Microscope operation instruction	5
Method of lens parfocal and adjust center	6/7
1.Method of lens parfocal.....	6
2.The method of adjusting center.....	7

Cautions and Notes

1. To avoid lens staining or scratching, please do not touch the lens directly with your finger.
2. To avoid the impact of failure on use, please do not disassemble or modify the internal structure of the device.
3. Do not use organic solvents to clean.
4. If the lens or sensor is dirty or damp, you can have mixed with industrial alcohol, ether with 1:1 ratio. And should better use dry and non-linen fabric or professional lens tissue to wipe them.
5. Do not use or place microscope in high temperature and humidity environment, direct sunlight or near heat sources, dusty places, and shaking places for a long time.

Suitable working temperature and humidity

Working humidity 20%~80%

Working temperature 0°C~40°C

6. In order to avoid possible electric shock accidents, please unplug the power supply before moving microscope

Microscope Specification

Main Feature

1. FM3D0325U 3D video microscope body based on infinity optical system.
2. Manual switch 2D and 3D observation freely, 360 °rotation, 45 °objective viewing angle.
3. Working distance always maintain 86mm when you switch 2D and 3D observation, No need to adjust the focus.
4. The center position of 2D and 3D is same, Zoom to any magnification have a best image without adjustable.
5. CCD adaptor with fine-tuning device, it can match any CCD camera, when you fine-tuning, camera and lens no need to rotate.
6. At Minimum magnification, the field of view is full image without dark edge image, high resolution, large depth of view.
7. High resolution 1:8.3 zoom lens. It can satisfy the requirements of observation range and magnification
8. 1/2 SONY 1080P HDMI smart camera. No need computer no need installs software. Support pictures to U disk
9. Widely used in microelectronics, precision electronics, precision hardware, deep hole wall, life science, morphology, forensic identification.

Optical Parameter

Lens parameter	Optical mag.	0.3-2.5X, 1:8.3 ratio
	Total mag.	11-95X
	Working distance	86mm
	FOV	24*13.5-2.88*1.62mm
2D/3D Rotation view	2D/3D manual switch freely	
	Working distance always remain same	
	The center position remain same	
	360 °rotation, 45 °objective viewing angle	
Camera parameter	Image Sensor	1/2"
	Resolution	1920 x 1080
	Pixel size	3.75µm
	Frame	60fps
	Color control	Manual/auto
	Brightness control	Manual/auto
	Record format	Snapshot, Picture Format: JPG or BMP Resolution:1920x1080
	Image output	HDMI
Monitor parameter	Size	12.5"
	type	a-Si TFT-LCD/IPS
	Resolution	1920*1080
	Color display	16.7M
	Brightness	300 Nit
	Contrast	800:1
	Power supply	Adapter:Input:AC100~240V/50~60 Hz;Output:DC12V/5A/60W Monitor: USB-A- Output:DC5V/2Ax3
	Image input	HDMI1,HDMI2
Light parameter	Light Control	4 zones control. Brightness adjustable
	Light color	White
	Quantity of LED	208PCS
	Intensity	15000 Lux
	Wavelength	455-457.5nm
	Output voltage	12V
	Output power	8-10W
	Working distance	35-110mm
	Material	Aluminum alloy
Diameter	Inner diameter 40mm, outer diameter 106mm, height 19mm	
Stand parameter	Base size	330*300mm
	Height	328mm
	Scope dia.	50mm

Microscope structure and components

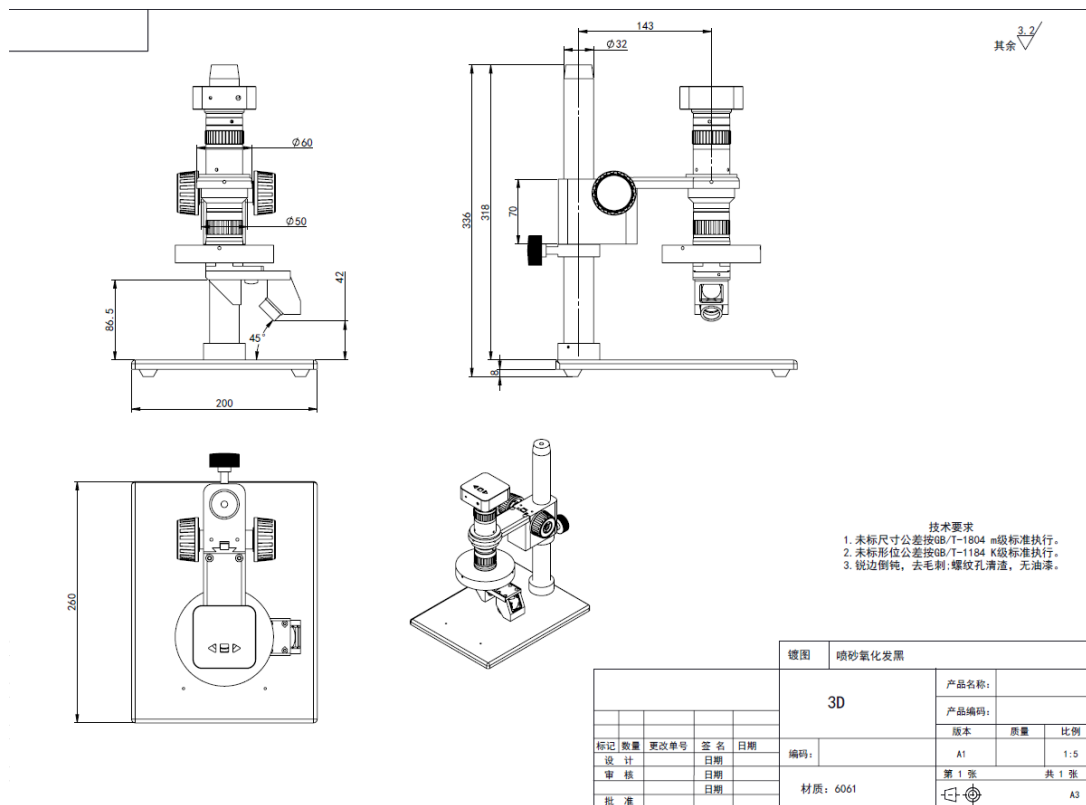

1. stand base 2.2D/3D rotation view 3.4 zones control LED ring light .4. Zoom body 5.CCD fine focus tube 6.HDMI camera 7. stand post 8. Focusing holder

2. Microscope Install Instructions

1. Open the package and take out all accessories carefully.
2. Install stand. Firstly, install the column on the base
3. Install display with post and tighten the screw to fix it.
4. Fixed the fixed towing ring into post, and then install the focusing holder with post. tighten the screw to fix to appropriate height.
5. Install camera with the upper end of the lens
6. Put the lens into focusing holder. Face the zoom marking line to the user. fix the lens with wrench.
7. Connect the four-zone ring light source with the front end of zoom body. First, loosen the three knurling screw on light, then fasten it.
8. Install 2D/3D rotating viewer into the bottom of the lens and fix it with wrench.

9. Connect camera with display by HDMI cable. Connect camera with 12V power light. One USB port with mouse other USB port with U disk. Also connect display and LED ring light with 12V power supply

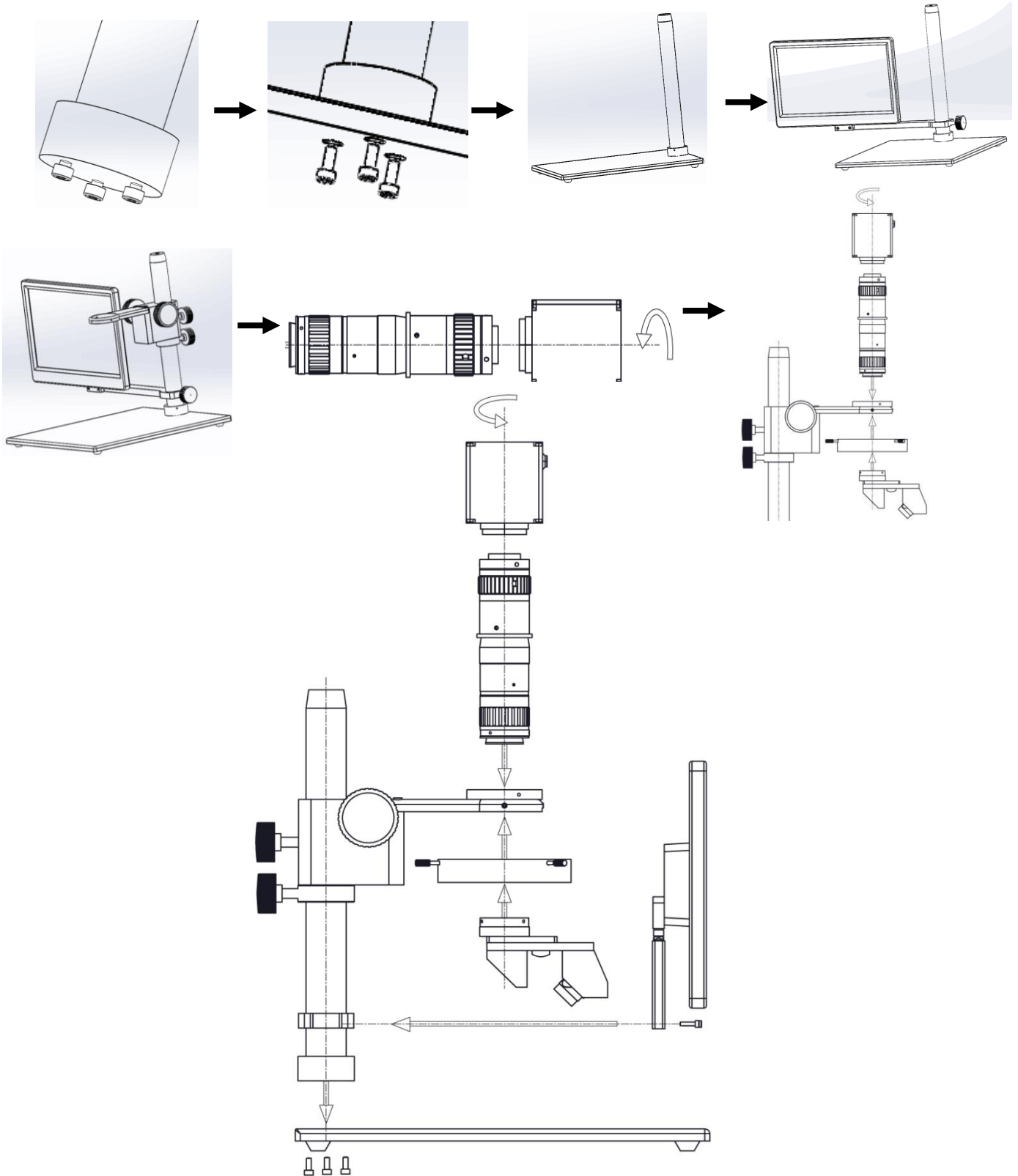

Microscope operation instruction

1. After installing microscope well. Turn on the power supply.
2. When the power is turned on, the camera power indicator is green and the display power indicator is blue.
4. Open power of four-zone light source select the area light source and adjust the brightness according to the need. (Note: try not to keep the brightness in the brightest state for a long time, so as not to reduce the service life)
5. Adjust lens to max magnification 5.0X. Adjust the focus holder. The working distance is about 86 mm. At this time, the image will appear on the display screen. Attention to increase or decrease the brightness of the light source to make the image in the clearest state.
6. Adjust lens to min magnification 0.6X. At this time, the image is not clear. Adjust CCD fine focusing tube to let the image is the clearest.
7. Repeat more than 5.6 steps twice, finish lens perforal. Adjust each magnification has a clear image.
8. Then we can observe with 2D or 3D

Special tips: 3D observation. Users need push 2D/3D rotation viewer 2D observation position. Adjust the zoom lens to 0.6X and put the position of observing part to the center of display screen. Then adjust the focusing holder let the image clear. Then adjust the zoom lens up 0.6X. Pull to 3D observation position. The screen will present a clear 3D picture. Users can 360° rotation observation. Also can adjust zoom lens magnification to observe. The image will remain clear and no longer need to focus again

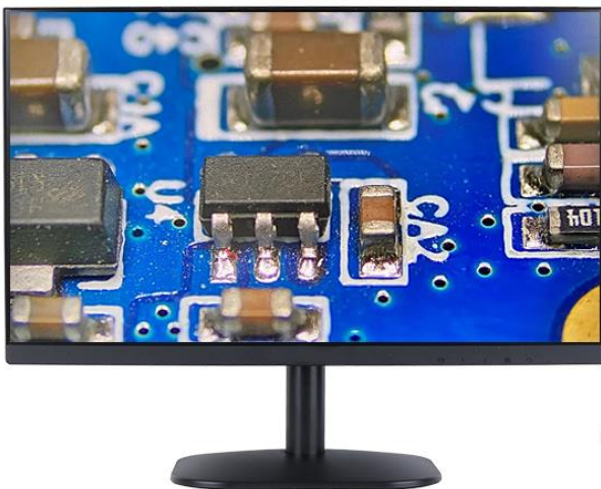

Method of lens parfocal and adjust center

Since it is not possible to ensure that chip position of each camera is as same as the center. So it is necessary to adjust the lens in order to ensure the image center of each magnification in the center of the display before using.

1.Method of lens parfocal

1) User can prepare an objective scale with crosshair



2) Firstly, Put the scale under the lens. Adjust the lens to max magnification 5X (Adjust the **zoom body hand wheel 1**). Then adjust **focus holder hand wheel 2** to suitable working distance(Standard working distance is about 86mm).Let the image become clearest.

3) Second. Adjust the lens to min magnification 0.6X(Adjust zoom body hand wheel) At this time, the image is not clear. Adjust **CCD fine focus hand wheel 3**. Let the image become clearest, and the center of the crosshair image is 4.

4) Repeat 2).3) steps more than two times, Lens parfocal is OK. That is to say, every magnification has a clear image

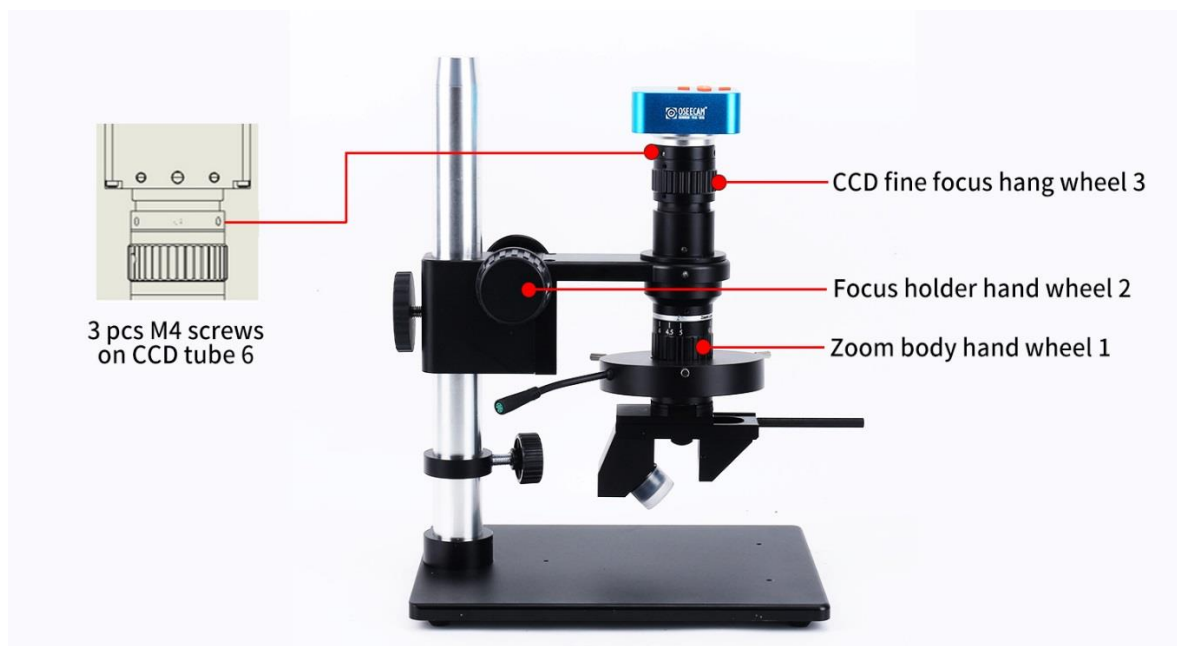

2.The method of adjusting center

- 1)Before adjusting the center. Users must be finish lens parfocal.
- 2)Turning on the camera's cross function, we can see that the center of the crosshair on the display is the center of the display. If the camera does not have cross-line function, you can manually mark the center of the display to represent the center (the center is 5).



- 3) Put the scale under the lens. Adjust the lens to max magnification 5X (Adjust the **zoom body hand wheel 1**). Then adjust **focus holder hand wheel 2** to suitable working distance(Standard working distance is about 86mm).Let the image become clearest. Move the center of the crosshair 4 of objective scale to the center 5 of the display crosshair on the display, let the center 4 and 5 coincide precisely.
 - 4)Then adjust lens zoom body hand wheel 1 to min magnification 0.6X. At this time, the center 4 will shift the center 5. Then loosen **3pcs M 4 screws on CCD tube 6**. According to the image migration law, lock the three M 4 screws, move the center 4 to the center 5, and make the center 4 and the center 5 coincide accurately.
- Repeat step 3) and 4) twice. Adjust center is OK. That is to say, the center of 2D and 3D observation remain same

